

*A. Stoeckel,*  
*Turning Regular Forms.*

*N<sup>o</sup> 13,236.*

*Patented July 10, 1855.*

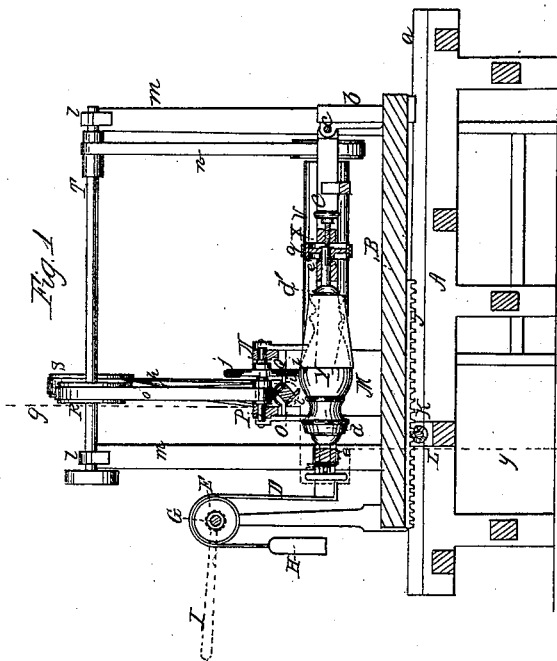
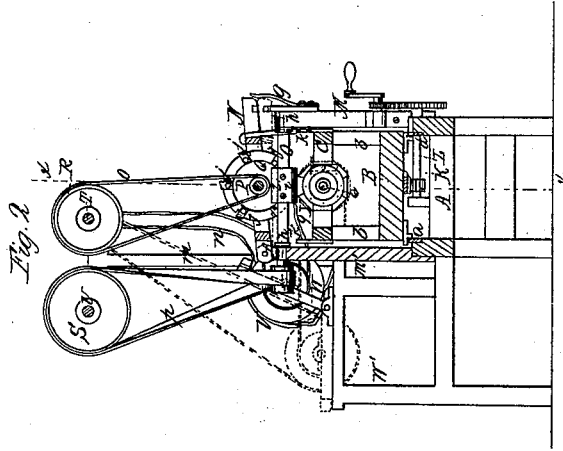

# UNITED STATES PATENT OFFICE.

ANDREW STOECKEL, OF NEW YORK, N. Y.

MACHINE FOR CUTTING LEGS FOR PIANOS, TABLES, &c.

Specification of Letters Patent No. 13,236, dated July 10, 1855.

*To all whom it may concern:*

Be it known that I, ANDREW STOECKEL, of the city, county, and State of New York, have invented a new and Improved Machine for Cutting Polygonal Legs or Pedestals for Tables, Pianofortes, &c.; and I do hereby declare that the following is a full, clear, and exact description of the same, reference being had to the annexed drawings, making a part of this specification, in which—

Figure 1, is a longitudinal vertical section of my improvement, (x) (x) Fig. 2, showing the plane of section. Fig. 2, is a transverse vertical section of ditto, (y) (y) Fig. 1, showing the plane of section.

Similar letters of reference indicate corresponding parts in the two figures.

This invention relates to a new and useful machine for cutting legs or pedestals of polygonal form, for tables, pianofortes, etc.

A, represents a frame on the upper part of which are two guides (a), (a), on which a carriage B, works. One end of this carriage B, has two uprights (b) (b) secured to it, and to the upper parts of these uprights there is attached by hinges (c) one end of a frame C, within which the "stuff" to be operated upon is centered similar to the way in which articles are centered in an ordinary turning lathe, see Fig. 1, in which (d) (d') represent the center points and (e) (e') the mandrels to which the center points are attached. To the opposite end of the frame C, there is attached a band D, which passes over a pulley E, on a shaft G, which works in the upper ends of uprights on the carriage B. The end of the band D, has a weight H, attached to it, and one end of the shaft G, is provided with a lever I, as shown by dotted lines Fig. 1. The under side of the carriage B, has a rack J, attached to it, in which rack a pinion K, on a shaft L, gears.

M, M', are uprights attached to the frame A. To one of these uprights M, one end of a frame N, is attached by hinges or joints (f). The opposite end of said frame when in a horizontal position rests upon the other upright M, and is secured by catches (g). There is also a shaft O, fitted in bearings (h) on the upper ends of the uprights M, M', and underneath the frame N, on this shaft cutters (i) (i) are secured.

The frame N, and shaft O, are placed transversely over the carriage B, and frame

C. On the frame N, there is attached a shaft P, having a circular disk Q, upon it to the periphery of which cutters (j) are attached, said cutters being of gouge form. To each side of the frame C, there is attached a pattern (k), see Fig. 2. These patterns are merely flat strips of metal attached to the sides of the frame C, and having their upper edges cut to correspond to the line or form or outline in which the article is to be cut or formed.

R, S, are pulleys hung on shafts T, U, which work in suitable bearings (l) supported by uprights (m), (m), attached to the frame A.

V, is a drum which is hung in a swinging frame W, attached to a frame W', connected to one side of the frame A. This drum is driven by a belt (n) from the shaft T, and the disk Q, is driven by a belt (o), from the pulley R, on the shaft T. The cutter shaft O, is driven by a belt (p) from the pulley S, on the shaft U.

X, is a pulley on the mandrel or arbor (e'). Around this pulley a belt (q), passes said belt also passing around the drum V.

The "stuff" to be operated upon is placed or centered in the frame C, between the points (d) (d'). Y, represents the stuff. The frame C, having been previously moved to the right as far as it is intended to go so as to bring the disk Q, over the end of the stuff Y. Motion is then given the shaft T, in any proper manner and the cutter disk Q, drum V, and the stuff Y, is rotated. The carriage B, is then moved along on the upper part of the frame A, from right to left by turning the shaft L, by hand and the frame C, and stuff Y, is raised and lowered by the pattern or rather by means of projections attached to the frame N, against which the pattern bears, the frame C, being kept elevated by operating the lever I, by hand, and the stuff Y, will consequently be turned in form corresponding to the patterns.

When the "stuff" is turned, the frame N, is raised in order to free the stuff from the cutter disk and the drum V, is also raised or the swinging frame to which the drum is attached. The carriage B, is then moved back to its original position and the "stuff" Y, secured between the points (d) (d') in any proper manner so that it cannot casually turn thereon. The frame C, is then again raised by operating the lever I, and motion is given the shaft U, in any proper manner

and the shaft O, and cutters (*i*) rotate and the carriage B, is moved as before by turning the shaft L, and the cutters (*i*) will cut or plane a flat surface on the "stuff" Y. The carriage B, is then moved back to its original position and the "stuff" Y, turned on or between the points (*d*) (*d'*) a certain distance and a second flat surface is planed. The operation is repeated till the whole surface of the "stuff" is planed or cut in polygonal form.

The above machine is extremely simple and works rapidly and well. The "stuff" is not taken from the machine until finished and therefore no time is lost by repeated handling as is now required in order to effect the same purpose.

I do not claim turning the "stuff" the required form by means of patterns for that has been previously done, neither do I claim the cutter disk Q, nor the rotating cutters (*i*), (*i*), but,

What I do claim as new and desire to secure by Letters Patent, is—

The arrangement of the carriage B, with the vibrating frame C, attached, cutter disk Q, and cutters (*i*), (*i*), on the shaft O, and drum V, placed in the swinging frame W, substantially as herein shown for the purpose set forth.

ANDREW STOECKEL.

Witnesses:

JOS. GEO. MASON,  
WM. TUSCH.